

LCT
(Machine Code: A862/B391)

1. OVERALL MACHINE INFORMATION

1.1 SPECIFICATIONS

Paper Size:	A4 sideways/LT sideways
Paper Weight:	60 g/m ² ~ 105 g/m ² , 16 lb ~ 28 lb
Tray Capacity:	2,000 sheets (80 g/m ² , 20lb)
Remaining Paper Detection:	5 steps (100%, 75%, 50%, 25%, Near end)
Power Source:	24 Vdc, 5 Vdc (from copier/printer)
Power Consumption:	26 W (Max.)/14 W (Ave.)
Weight:	25 kg (55 lbs)
Size (W x D x H):	550 mm x 520 mm x 271 mm

1.2 MECHANICAL COMPONENT LAYOUT

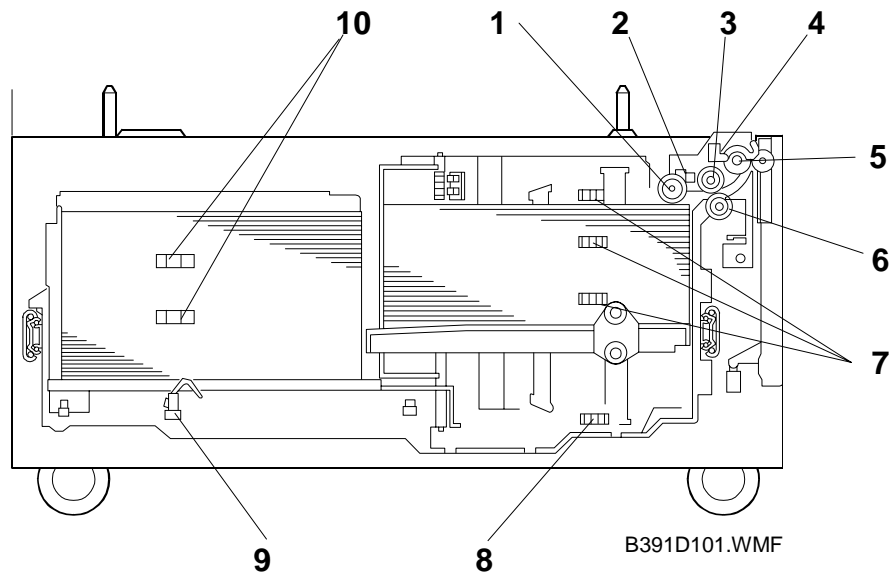

- | | |
|-----------------------|---------------------------------|
| 1. Pick-up Roller | 7. Paper Height Sensors 1, 2, 3 |
| 2. Upper Limit Sensor | 8. Lower Limit Sensor |
| 3. Paper Feed Roller | 9. Left Paper End Sensor |
| 4. Relay Sensor | 10. Paper Height Sensors 4,5 |
| 5. Relay Roller | |
| 6. Reverse Roller | |

1.3 ELECTRICAL COMPONENT LAYOUT

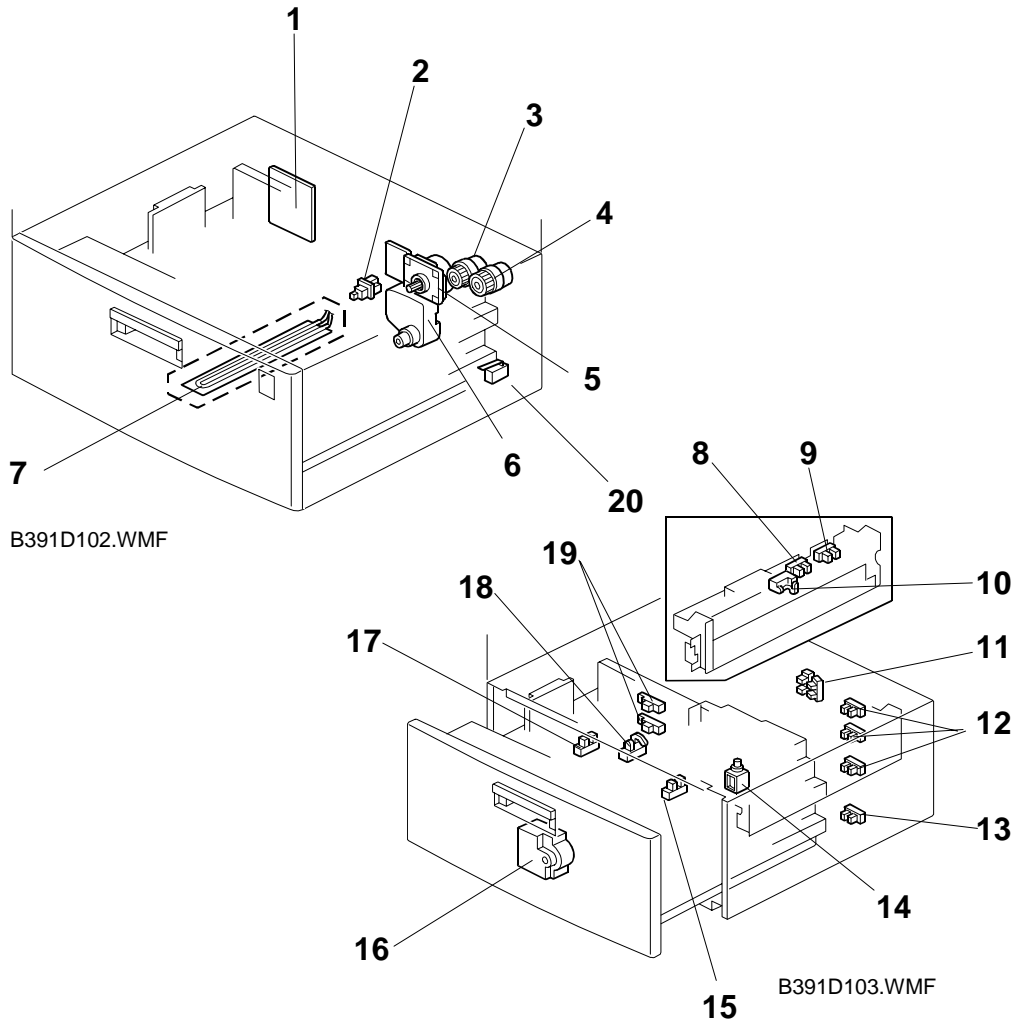

- | | |
|------------------------------------|-------------------------------------|
| 1. Main Board | 12. Paper Height Sensors 1, 2, 3 |
| 2. Tray Sensor | 13. Lower Limit Sensor |
| 3. Relay Clutch | 14. Side Fence Solenoid |
| 4. Paper Feed Clutch | 15. Rear Fence Return Sensor |
| 5. Tray Motor | 16. Rear Fence Motor |
| 6. Tray Lift Motor | 17. Rear Fence Home Position Sensor |
| 7. Tray Heater (option) | 18. Left Tray Paper End Sensor |
| 8. Right Tray Paper End Sensor | 19. Paper Height Sensors 4, 5 |
| 9. Upper Limit Sensor | 20. Right Cover Switch |
| 10. Relay Sensor | |
| 11. Side Fence Open/Closed Sensors | |

Options

1.4 ELECTRICAL COMPONENT DESCRIPTIONS

Symbol	Name	Function	Index No.
Motors			
M1	Tray Motor	Drives all rollers.	5
M2	Tray Lift Motor	Drives the paper tray up or down.	6
M3	Rear Fence Motor	Moves the rear fence to transfer the paper stack from the paper storage (left) side of the tray to the paper feed (right) side.	16
Sensors			
S1	Right Tray Paper End	Informs the copier/printer when the paper in the right side (paper feed side) of the tray has been used up. If there is a paper stack in the left side (paper storage side), this is moved into the right tray. If there is no paper stack in the left side, paper end is indicated.	8
S2	Relay	Detects the copy paper coming to the relay roller and checks for misfeeds.	10
S3	Upper Limit	Detects when the paper is at the correct paper feed height.	9
S4	Lower Limit	Detects when the tray is completely lowered, to stop the LCT motor.	13
S5	Paper Height 1, 2, 3	Detects the amount of paper remaining in the right side of the tray.	12
S6	Paper Height 4, 5	Detects the amount of paper remaining in the left side of the tray.	19
S7	Rear Fence Home Position	Detects when the rear fence is at H.P.	17
S8	Tray	Detects whether the tray is correctly set.	2
S9	Side Fence Open/Closed	Detects whether the side fence is opened on closed.	11
S10	Rear Fence Return	Detects when the rear fence has moved the paper stack from the left side to the right side.	15
S11	Left Tray Paper End	Informs the copier/printer when there is no paper in the left side (paper storage side) of the tray.	18
Solenoids			
SOL1	Side Fence	Controls open-close movement of the side fence.	14
Magnetic Clutches			
MC1	Paper Feed	Drives the paper feed roller.	4
MC2	Relay	Drives the relay roller.	3
PCBs			
PCB1	Main	Controls the LCT and communicates with the copier/printer.	1
Switches			
SW1	Right Cover	Detects whether the right cover is open.	20

2. DETAILED SECTION DESCRIPTIONS

2.1 PAPER FEED

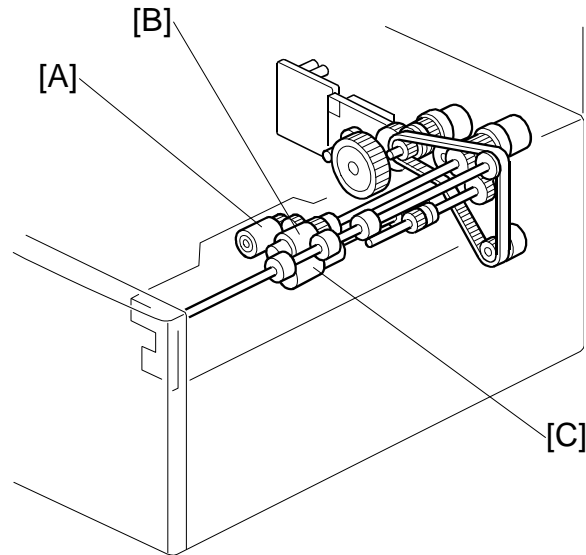

B391D104.WMF

This products uses an FRR type paper feed mechanism.

The paper feed unit consists of the pickup roller [A], paper feed roller [B], reverse roller [C], and grip and transport rollers.

There is a torque limiter in the back of the reverse roller (ferrite powder type).

2.2 REVERSE ROLLER AND PICK-UP ROLLER RELEASE

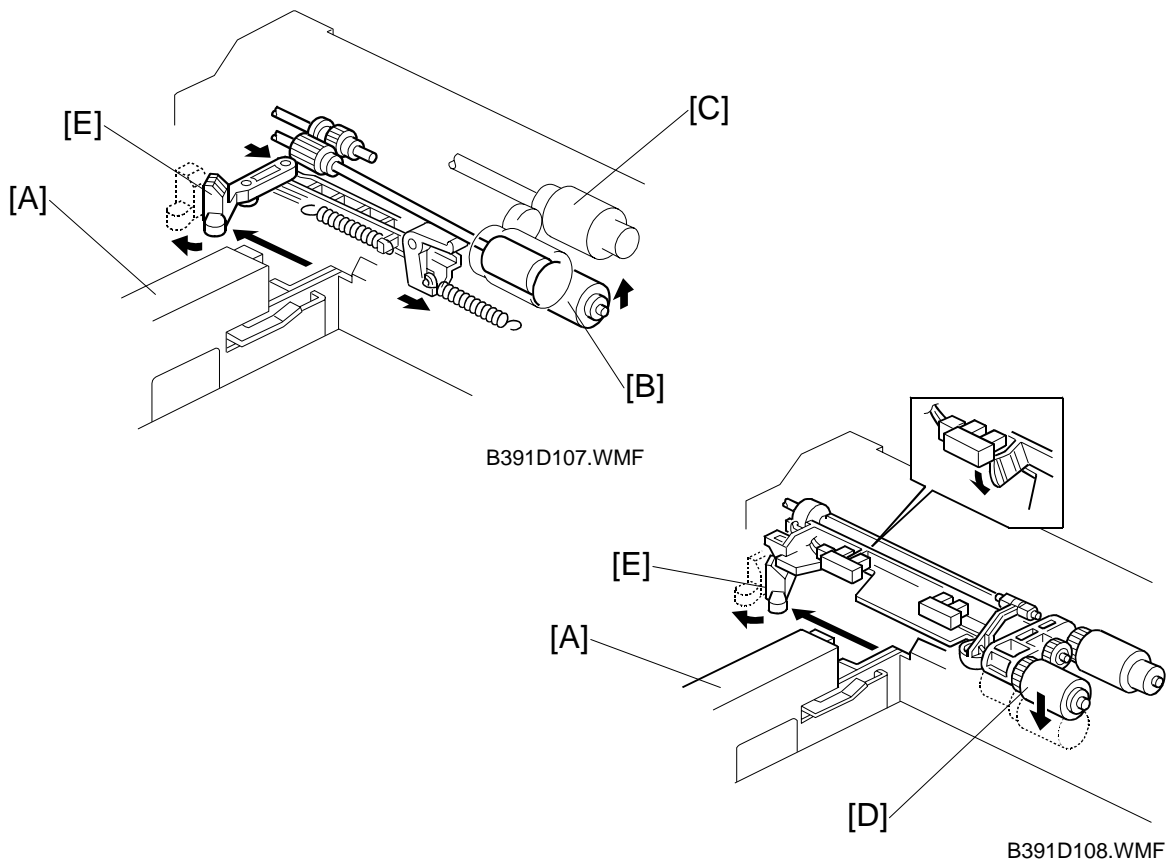

To prevent the paper from being torn when pulling out the paper feed tray, the reverse and pickup rollers are set so that they release automatically.

When the paper tray [A] is not inside the machine, the reverse roller [B] is away from the paper feed roller [C] and the pick-up roller [D] stays in the upper position.

When the paper tray is set into the machine, it pushes the release lever [E]. This causes the pick-up roller [D] to go down into contact with the top sheet of paper and the reverse roller [B] to move up and contact the paper feed roller.

2.3 TRAY LIFT

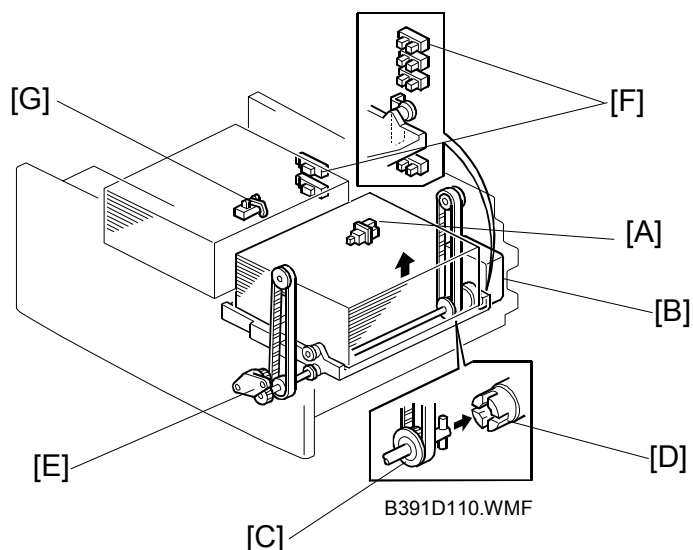

When the paper feed tray is put in the machine, the tray switch [A] on the back face turns on and the tray lift motor [B] starts up. The base plate lift shaft [C] is coupled to the lift motor at shaft [D], so the base plate of the tray is lifted. After a short while, the top of the paper stack contacts the pick-up roller and lifts it up.

When this occurs, the actuator enters the upper limit sensor, the sensor turns off and the lift motor stops. When paper in the tray is used up, the pick-up roller is gradually lowered, and the actuator leaves the upper limit sensor (turning the sensor on). When this happens, the lift motor begins turning again. The tray will then be lifted until the actuator enters the upper limit sensor (turning the sensor off again).

When the tray is removed from the copier, the coupling between the lift motor [B] and base plate lift shaft [C] is broken and the base plate goes into a controlled free fall (using a damper [E] to slow the fall and prevent damage).

2.4 NEAR END/END DETECTION

This tray can hold two stacks of paper, so the machine needs to monitor the status of both these stacks. There are seven sensors to do this.

In the right tray (paper feed side), three height sensors measure the height of the stack, and an end sensor detects when all the paper is used up. As the amount of paper remaining in the tray decreases, the base plate rises and the actuator activates the paper height sensors. When paper runs out in the right tray, the stack in the left tray is moved across to the right tray.

There are also five height sensors ([F] in the diagram on the previous page) and an end sensor in the left tray (paper storage side) ([G] in the diagram on the previous page). When there is no paper in both trays, paper end is detected.

The machine determines the amount of remaining paper based on the sensor outputs, as shown in the following table.

Paper end sensor 1: ○ = Low (no paper), ● = High (paper present)
 Other sensors: ○ = Low (paper present), ● = High (no paper)

	Amount of paper								
	100%	75%		50%					
Paper Height Sensor 1	○	○	○	○	○	○	●	○	○
Paper Height Sensor 2	○	○	○	○	○	●	–	○	●
Paper Height Sensor 3	○	○	●	○	○	–	–	●	–
Paper End Sensor 1	●	●	●	●	●	●	●	●	●
Paper Height Sensor 4	○	●	○	●	●	○	○	●	●
Paper Height Sensor 5	○	○	○	●	●	○	○	○	○
Paper End Sensor 2	○	○	○	○	●	○	○	○	○

	Amount of paper							
	25%					Near-end		End
Paper Height Sensor 1	●	○	○	○	○	●	●	–
Paper Height Sensor 2	–	–	●	○	●	–	–	–
Paper Height Sensor 3	–	–	–	●	–	–	–	–
Paper End Sensor 1	●	●	●	●	●	●	●	○
Paper Height Sensor 4	○	●	●	●	●	●	●	●
Paper Height Sensor 5	●	○	●	●	●	●	●	●
Paper End Sensor 2	○	○	○	●	●	○	●	●

The following diagram is the sensor layout, as viewed from the front.

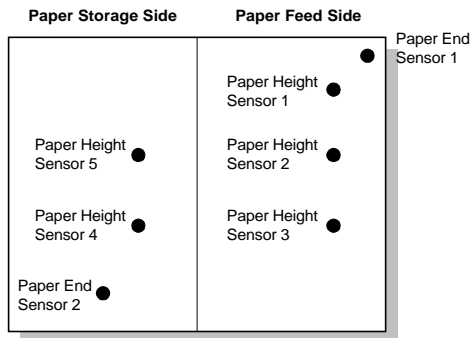

B391D112.WMF

2.5 RIGHT TRAY SIDE FENCE

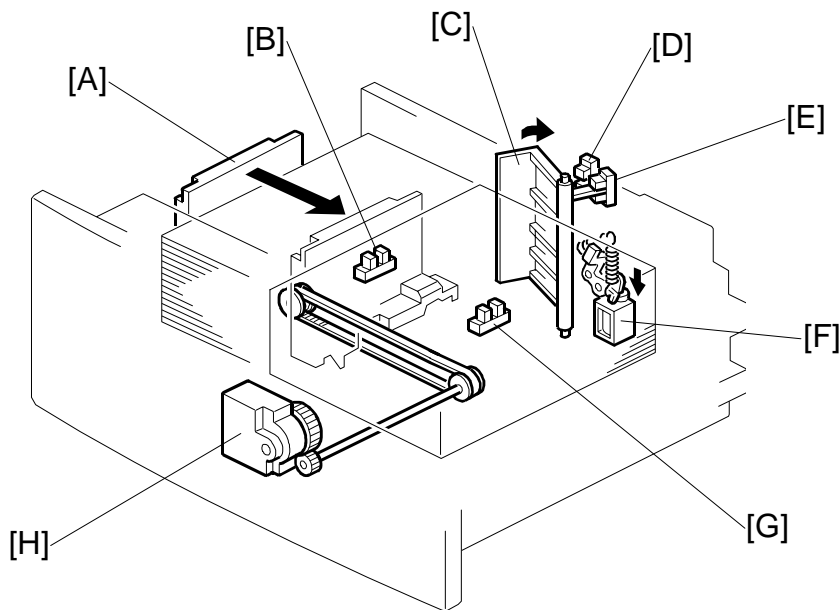

B391D109.WMF

When the paper in the right tray is used up, the side fence solenoid [F] activates and stays on until the side fence open/closed sensor [E] detects that the fence is open. The rear fence [A] then moves the stack of paper from the left tray into the right tray, as described in the following section. When the stack has been transferred to the right tray, the rear fence return sensor [G] detects the rear fence and then the cpu turns off the side fence open solenoid (closing the side fence).

The side fence open/closed sensor [D] detects when the side fence is closed. When it is not closed, the user is prompted at the operation panel to free the mechanism.

2.6 LEFT TRAY REAR FENCE

If the right tray paper end sensor detects that there is no paper in the tray (while the left tray sensor detects that there is still paper in the left tray), the right side fence [C] opens and the rear fence motor [H] turns on. The rear fence of the left tray moves and the paper stack is then transferred from the left tray to the right tray.

When the left tray rear fence activates the rear fence return sensor, the machine detects that the paper stack has been transferred to the right tray and the rear fence motor rotates in the opposite direction. When the rear fence HP sensor [B] comes on, the motor stops.

2.7 RIGHT TRAY PAPER END DETECTION

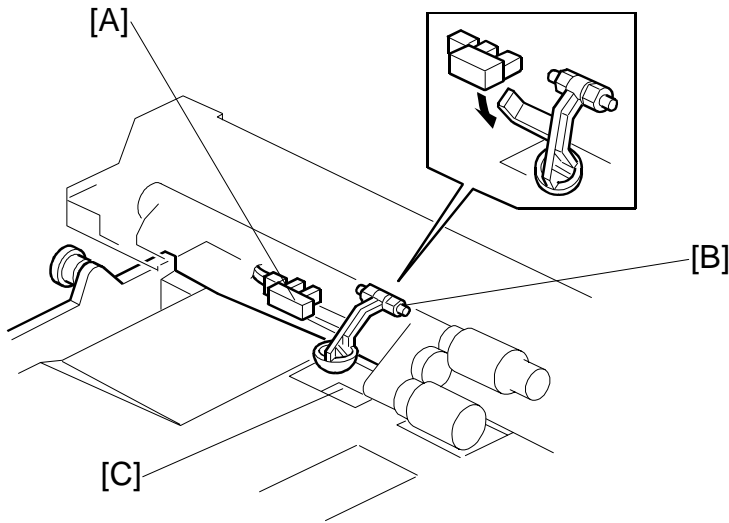

B391D106.WMF

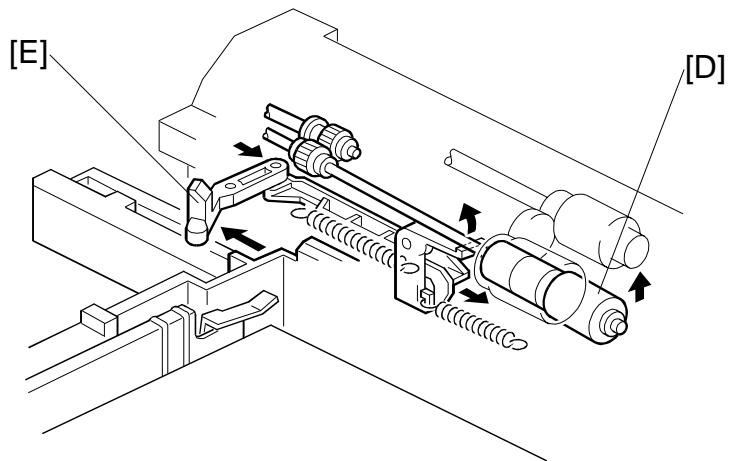

B391D111.WMF

The paper end sensor [A] detects when copy paper in the right tray runs out.

When there is paper in the tray, the paper pushes up the paper end feeler [B] and causes the actuator to come between the LED and photo diode of the sensor.

When paper runs out, the feeler drops and the actuator leaves the photointerruptor, and the machine detects that there is no paper in the tray.

When the tray is being pulled out, the lever [E] lifts the pick-up roller and this also lifts up the feeler.

3. REPLACEMENT AND ADJUSTMENT

3.1 DETACHING THE TRAY FROM THE MAINFRAME

While pressing the stopper attached to the guide rail, pull out the large capacity tray.

NOTE: When reinstalling the tray, set the tray on the guide rail and carefully push the tray in, making sure to keep the tray level.

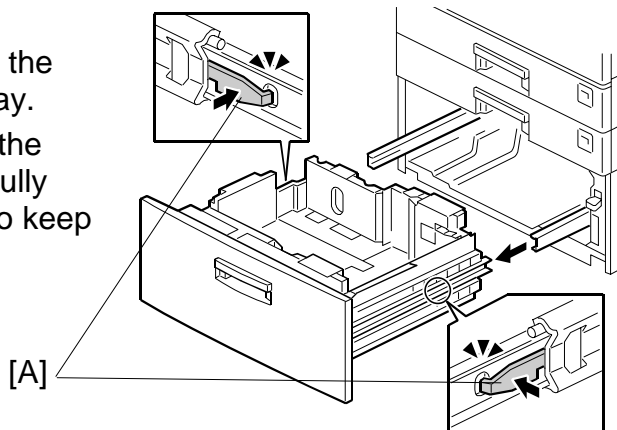

B391R101.WMF

3.2 REAR FENCE HP SENSOR

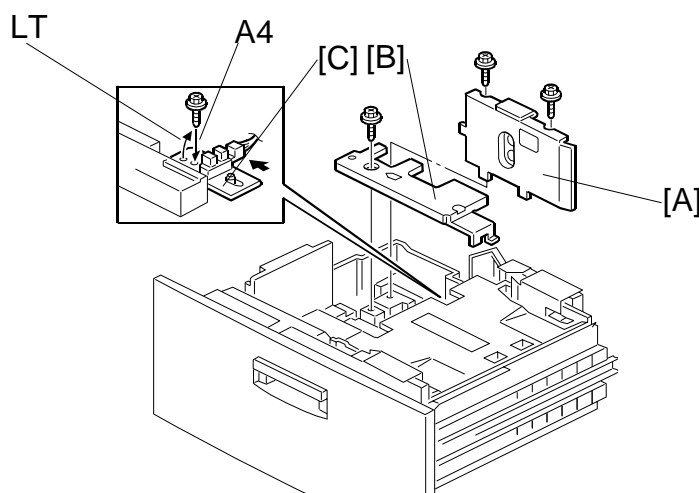

B391R102.WMF

1. Pull out the large capacity tray.
2. Remove the left tray rear side fence [A] (2 screws).
3. Remove the rear fence bracket [B] (1 screw).
4. Remove the connector of the rear fence HP sensor.
5. Replace the rear fence HP sensor [C] (1 screw).

NOTE: When securing the sensor in place, be sure to fasten the screw in the proper position.

3.3 CHANGING THE TRAY PAPER SIZE

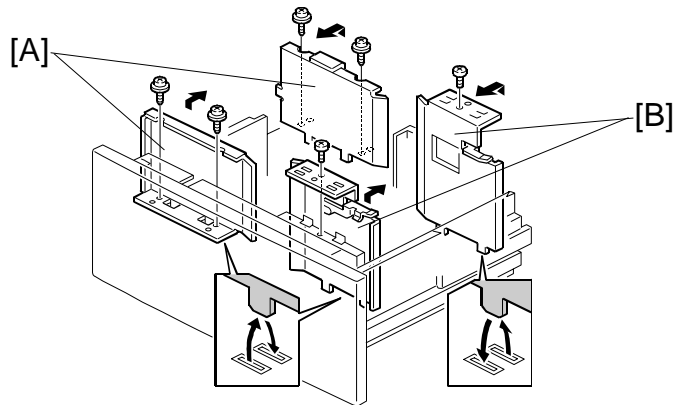

B391R103.WMF

1. Remove the screws of all side fences [A], [B].
2. The position of the rear fence HP sensor can then be changed (see Rear Fence HP Sensor Removal).
3. The paper size display can then be changed with an SP mode.

NOTE: When securing the right tray side fence, fasten the screw after setting the paper in the right tray and adjusting the fence to the width of the paper.

3.4 LEFT TRAY PAPER END SENSOR

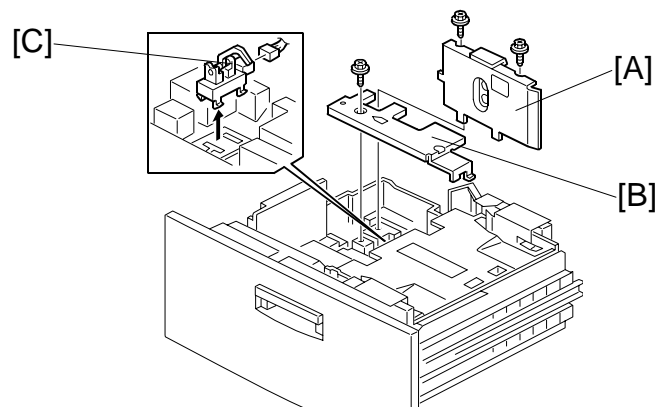

B391R104.WMF

1. Pull out the large capacity tray.
2. Remove the left tray side fence [A] (2 screws).
3. Remove the rear fence bracket [B] (1 screws).
4. Replace the left tray paper end sensor [C] (1 connector).

3.5 TRAY LIFT MOTOR

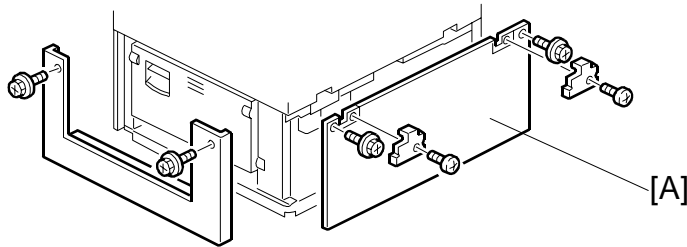

B391R105.WMF

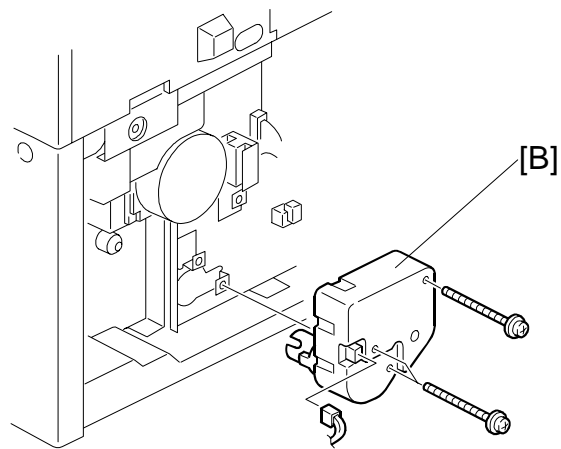

B391R106.WMF

1. Remove the brackets (1 screw for each).
2. Remove the rear cover [A] (2 screws).
3. Remove the tray lift motor [B] (3 screws, 1 connector).

3.6 TRAY MOTOR

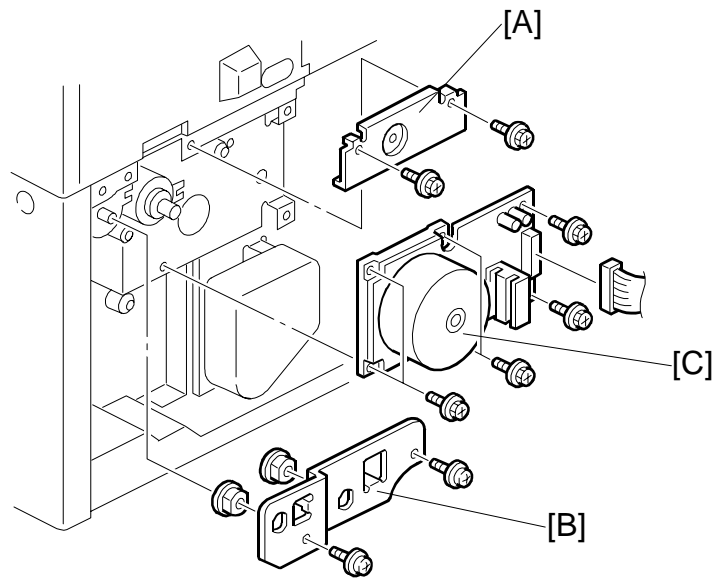

B391R107.WMF

1. Remove the rear cover.
2. Remove bracket #1 [A] (2 screws).
3. Remove bracket #2 [B] (2 screws).
4. Remove the tray motor [C] (6 screws, 1 connector).

3.7 PAPER FEED CLUTCH AND RELAY CLUTCH

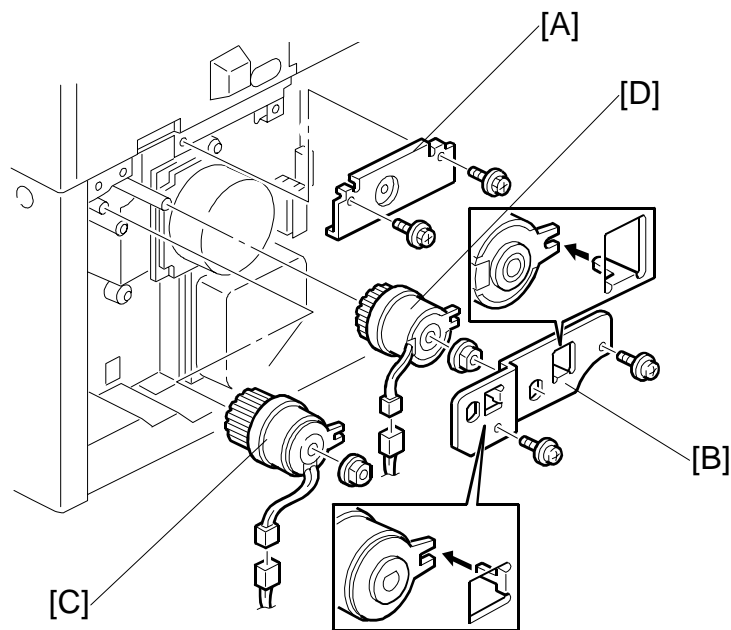

B391R108.WMF

1. Remove the rear cover.
2. Remove bracket #1 [A] (2 screws).
3. Remove bracket #2 [B] (2 screws).
4. Remove all bushings.
5. Remove the paper feed clutch [C] and relay clutch [D].
6. Replace the required clutch.

NOTE: Make sure to properly secure both clutches before completing installation.

3.8 PAPER FEED UNIT

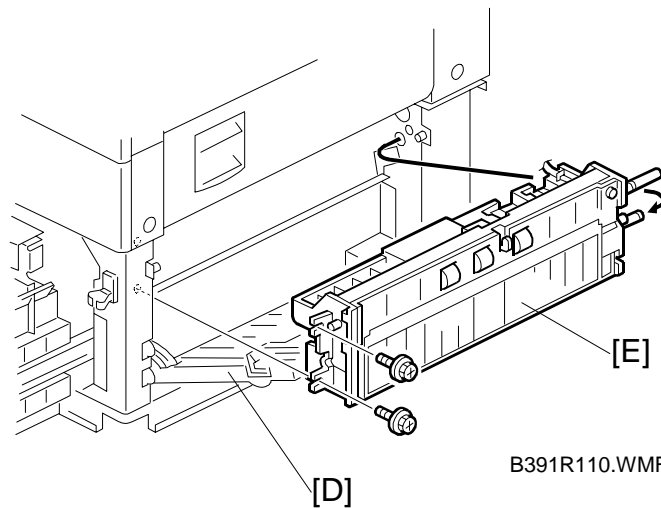
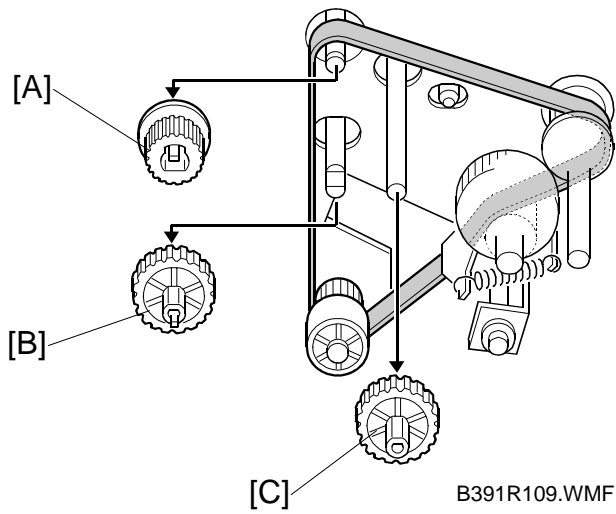

1. Remove the paper feed clutch and relay clutch (see Paper Feed Clutch and Relay Clutch Replacement).
2. Remove pulleys A [A], B [B], and C [C].
3. Remove the paper feed harness from the main board.
4. Open the vertical transport guide plate [D].
5. Remove the paper feed unit [E] (2 screws).

3.9 UPPER LIMIT, RIGHT TRAY PAPER END, AND RELAY SENSORS

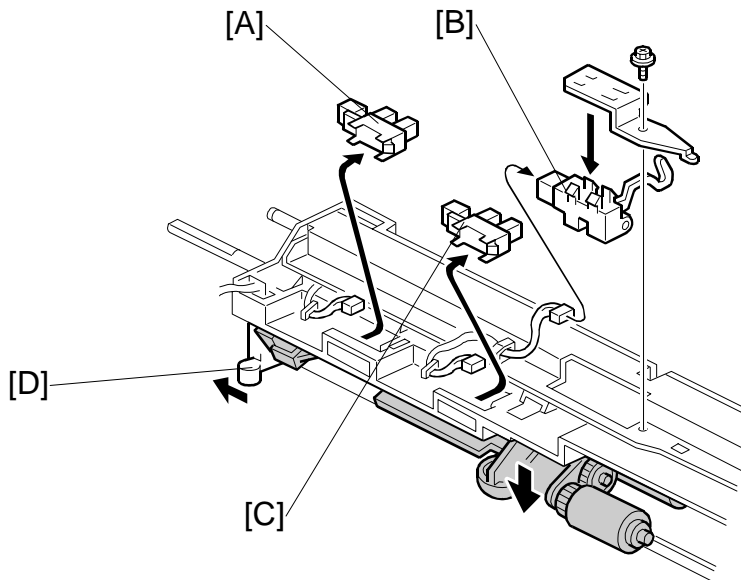

B391R111.WMF

1. Remove the paper feed unit (see Paper Feed Unit Replacement).
2. Replace the required sensor.
 - Upper limit [A]
 - Relay [B]
 - Right tray paper end [C]

NOTE: When replacing the upper limit [A] and paper end sensor [C], please be sure to do so while pushing the release lever [D].

3.10 REAR FENCE MOTOR

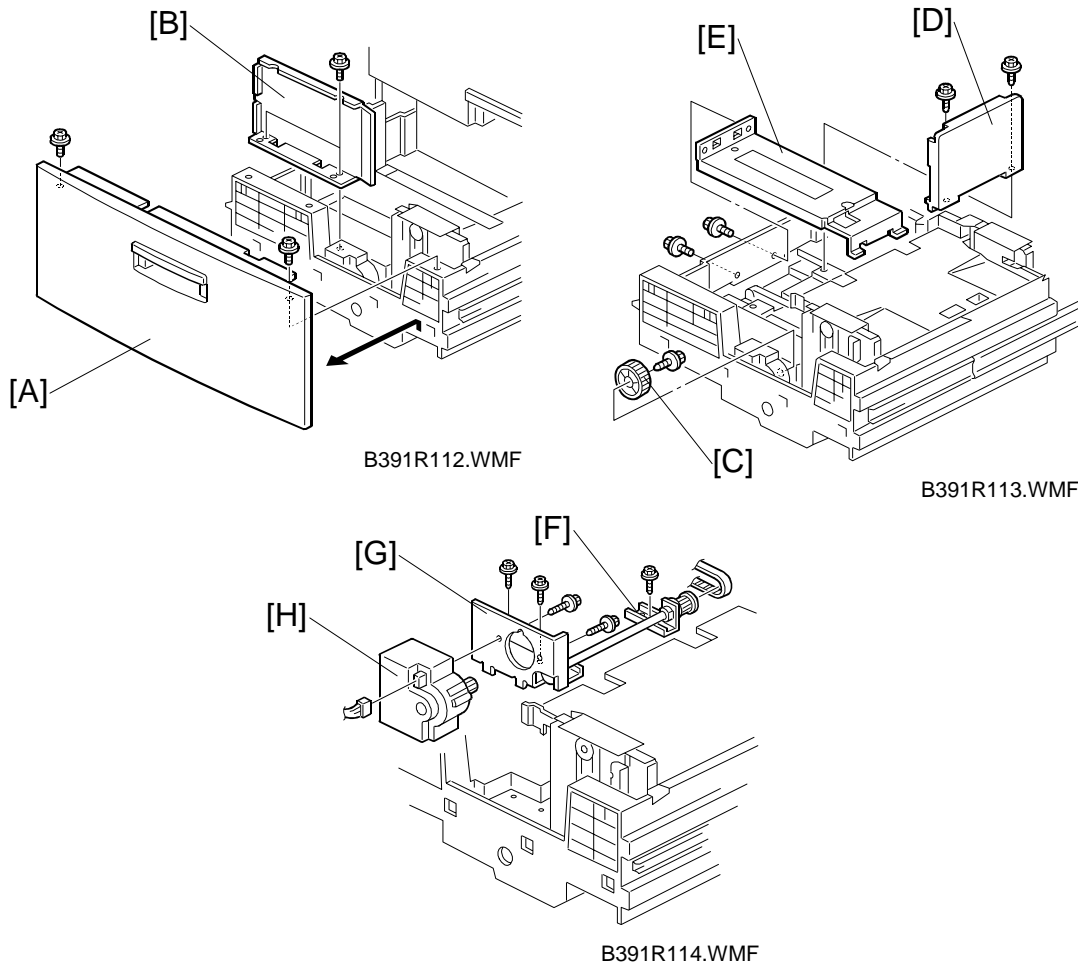

1. Pull out the paper feed tray unit.
2. Remove the paper feed tray front cover [A] (2 screws).
3. Remove the left side fence [B].
4. Remove the rear fence drive gear [C] (1 screw). This is in order to free the end fence [D].
5. Move the end fence to the right (toward the center).
6. Remove the end fence (1 screw).
7. Remove the end fence bracket [E] (2 screws).
8. Remove the bracket [F] (1 screw).
9. Remove the bracket [G] of the rear fence motor assembly (2 screws).
10. Remove the rear fence motor assembly (2 screws).
11. Replace the motor [H] (1 connector).

3.11 PICK-UP/PAPER FEED/REVERSE ROLLERS

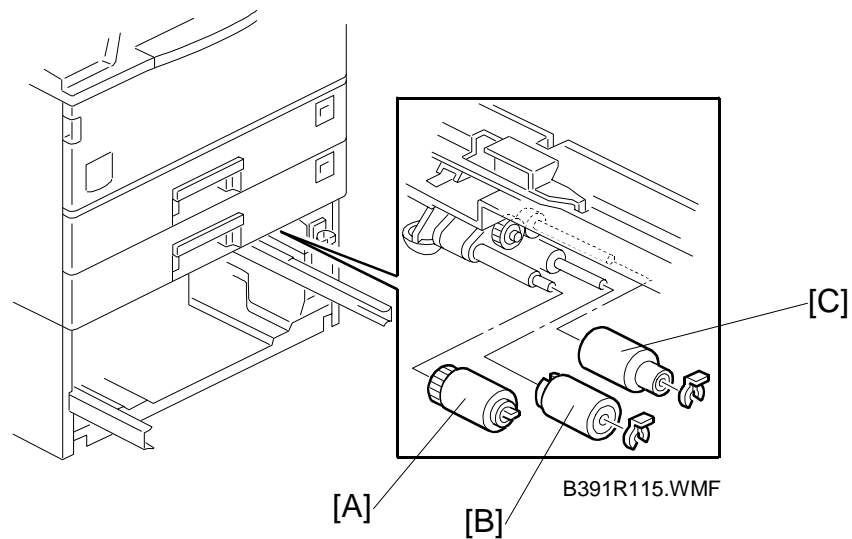

1. Remove the paper tray unit (see Paper Tray Unit Replacement).
2. Remove the snap ring (1 each for the paper feed and reverse rollers).
3. Remove the pick up roller [A].
4. Replace each roller [B], [C].

NOTE: Install the paper feed rollers the correct way round, as shown in the illustration. If the rollers are installed incorrectly, this will cause the one-way clutch to lock.